

Model 10

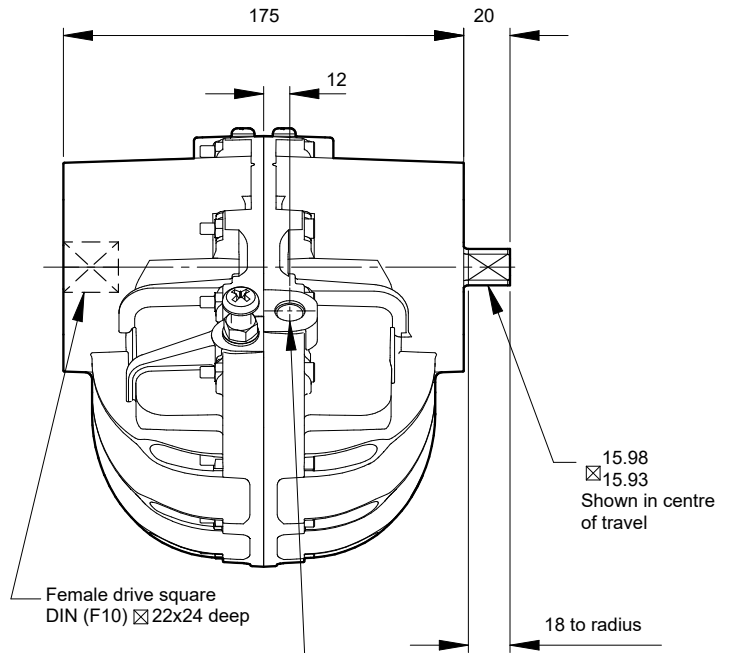

Specification

Output Torque

3625 lbf ins/416 Nm
at 100 psi/7 bar

Angle of Travel (adjustable)

78° - 100°
(restricted travel
versions available)

Displaced Volume

62.5 in³/1025 cm³

Finish

Epoxy stove enamel

Weight

11.9 lb/5.4 kg
(no coupling)

For further information
see General Specification
on page 5.

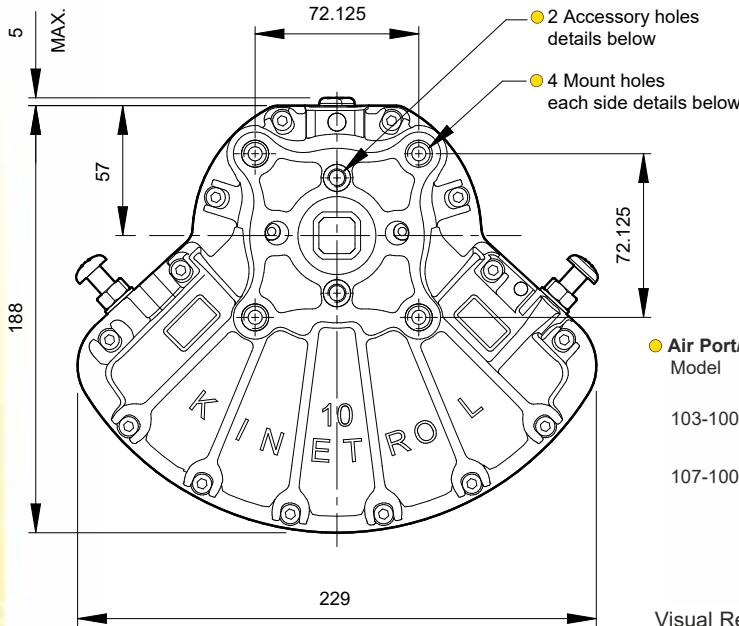

Air Port/Mount Hole Details

Model	Air Ports	Mount Holes & Accessory Mount Holes
103-100	G ¹ / ₄	4 x M10 x 16 deep on 102.0 PCD 2 x M8 x 16 deep on 50.8 PCD
107-100	1/4 NPT	4 x 3/8 - 16 UNC x 0.63" deep on 4.02" PCD 2 x 3/8 - 16 UNC x 0.63" deep on 2.00" PCD

Visual Red Indicator supplied as standard - see page 3

Options

- Fail safe spring return units - clockwise or counter clockwise see pages 27-29
- Limit switch boxes for open/close indication - various switches for hazardous areas see pages 31-34
- Integral solenoid valve see page 38
- AP pneumatic positioner - full range of options see pages 41/42
- EL electropneumatic positioner - full range of options see pages 39/40
- P3 on/off positioner- full range of options including hazardous area see pages 43-45
- Clear Cone position monitor see page 38
- Geared manual override see page 55
- Code identification see page 30
- Torque outputs see pages 6-8
- See pages 57-60 for English dimensions and dimensions of spring options
- High temperature / Low temperature options see page 5

