

Standard Coupling
(supplied with actuator
weight 0.37 lbs/0.17 kg)

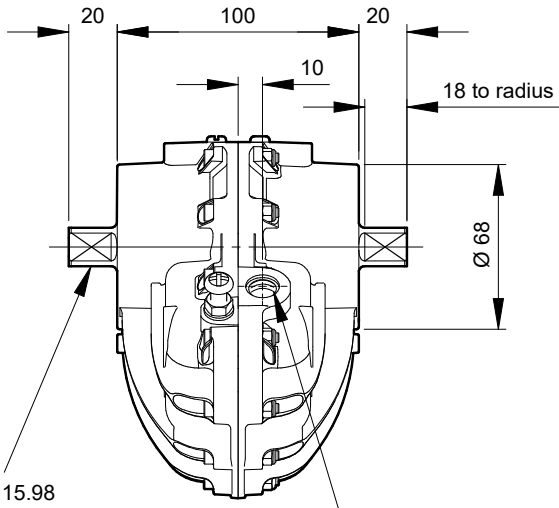

15.98
15.93
Both ends
shown at centre
of travel

2 Air ports staggered
thread details below

Air Port/Mount Hole Details

Model	Air Ports	Mount Holes & Accessory Mount Holes
074-100	G ¹ / ₄	4 x M8 x 16 deep on 50.9 PCD 2 x M8 x 16 deep on 50.8 PCD
077-100	1/4 NPT	4 x 5/16 -18 UNC x 0.63" deep on 2.00" PCD 2 x 5/16 -18 UNC x 0.63" deep on 2.00" PCD

Visual Red Indicator supplied as standard - see page 3

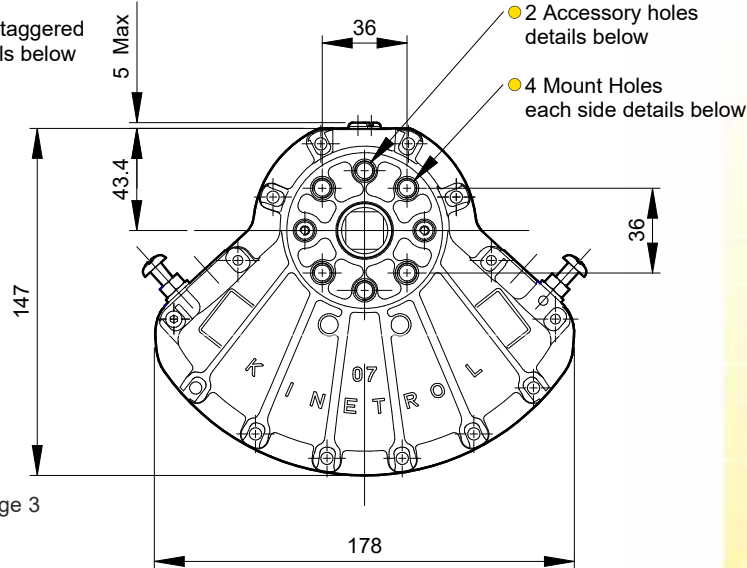

Specification

Output Torque

1080 lbf ins/124 Nm
at 100 psi/7 bar

**Angle of Travel
(adjustable)**

80° - 100°
(restricted travel
versions available)

Displaced Volume

18.3 in³/300 cm³

Finish

Epoxy stove enamel

Weight

3.97 lb/1.8 kg
(excluding coupling)

For further information
see General
Specification on
page 5.

Options

- Fail safe spring return units - clockwise or counter clockwise see pages 27-29
- Limit switch boxes for open/close indication - various switches for hazardous areas see pages 31-34
- Integral solenoid valve see page 38
- AP pneumatic positioner - full range of options see pages 41/42
- EL electropneumatic positioner - full range of options see pages 39/40
- P3 on/off positioner full range of options including hazardous area see pages 43-45
- Clear Cone position monitor see page 38
- 180° model see pages 51/52
- Female drive and mounting details to DIN 3337 and ISO 5211 see pages 57/58
- ISO adaptor see page 26
- G³/₈ or 3/8 NPT air port option available - contact Kinetrol
- Spring to centre see page 50
- Geared manual override see page 55
- Code identification see page 30
- Torque outputs see pages 6-8
- See pages 57-60 for English dimensions and dimensions of spring options
- High temperature / Low temperature options see page 5

